

## Installation, Operation and Maintenance Manual

Please read and save these instructions for future reference. Read carefully before attempting to assemble, install, operate or maintain the product described. Protect yourself and others by observing all safety information. Failure to comply with instructions could result in personal injury and/or property damage!



NEMA 4X  
304 Stainless Steel  
Enclosure



NEMA 3R  
16ga. Steel Enclosure

### Precautions and Warnings

To prevent injury and property damage, follow these instructions. Failure to adhere to installation/operation procedures and all applicable codes may result in hazards as indicated by warning codes outlined below:

#### DANGER

Indicates an imminently hazardous situation which, if not avoided, will result in death or serious injury. This signal word is to limited to the most extreme situations.

#### WARNING

Indicates a potentially hazardous situation which, if not avoided, could result in death or serious injury.

#### CAUTION

Indicates a potentially hazardous situation which, if not avoided, may result in minor or moderate injury. It may also be used to alert against unsafe practices.



This is the safety alert symbol. Read and follow instructions carefully to avoid a dangerous situation.



This symbol alerts the user to the presence of “dangerous voltage” inside the product that might cause harm or electrical shock.

## Table of Contents

<b>Installation</b>	
Mounting . . . . .	2
Wiring . . . . .	2
Low Voltage Wiring . . . . .	2
Torque Table . . . . .	2
<b>Wiring Schematic</b> . . . . .	2
<b>Program Switches</b> . . . . .	2
<b>Protective Features</b> . . . . .	3
<b>Electronic Overload Operation</b> . . . . .	3
<b>Operation</b> . . . . .	3
Keypad Interface . . . . .	3
Operation Modes . . . . .	3
LED Status Indicators . . . . .	3
<b>I/O Descriptions</b> . . . . .	4
<b>Our Commitment</b> . . . . .	4

## Safety Instructions

### DANGER

Equipment can start automatically. Lockout/tagout before servicing.

### CAUTION

As with all electrical products, read manual thoroughly. Only qualified, expert personnel should perform maintenance and installation. Contact the nearest authorized service facility for examination, repair, or adjustment. Do not disassemble or repair unit unless described in this manual; death or injury to electrical shock or fire hazard may result. Specifications and manual data subject to change. Consult factory for additional information.

### DANGER



#### HAZARDOUS VOLTAGE

- Disconnect and lock out all power before installing or servicing equipment.
- This equipment may require locking out multiple power sources prior to service.
- Install and wire in accordance with all applicable local and national electrical and construction codes.

### WARNING

**FAILURE TO FOLLOW THESE INSTRUCTIONS  
MAY RESULT IN DEATH OR SERIOUS INJURY.**

# Installation

## Mounting

Mount the starter on a vertical surface, with the line terminals facing up. Install using 1/4-inch diameter hardware suitable for the mounting surface.

### WARNING

- To maintain overcurrent and short circuit protection, the manufacturer's instructions for selecting current elements and setting the instantaneous-trip circuit breaker must be followed.
- Tripping of the instantaneous-trip circuit breaker is an indication that a fault current has been interrupted. Current-carrying components of the magnetic motor controller should be examined and replaced if damaged to reduce the risk of fire or electric shock.
- Do not locate starter in an environment subject to flammable gases, dusts or materials. Contact arcing can induce explosion or fire.
- Locate starter in a location appropriate to enclosure ratings and operational ratings. (e.g. NEMA-1 should only be located in a dry, protected environment).
- Do not allow any metal shavings or debris from installation to enter enclosure.

## Wiring

Wire main power input and motor leads to the appropriate terminals tightened to specified torques indicated in the torque table. Use only copper conductors rated at least 60°C for applications less than 100A and at least 75°C ≥ 100A. Maintain proper clearances and verify that no possibility of an electrical short exists between the power conductors or enclosure. Ensure that wires are not under stress and all insulation is intact. Verify voltage input matches label and the control power is tapped per schematic.

## Low Voltage Wiring

Automation system control wiring should be run in a separate conduit. The control terminals accept 26~14AWG wire torqued to 3.5 in-lb.

## Torque Table

NEMA Size	Input (lb-in)		Output (lb-in)
	Standard	Combination	Motor Leads
00	15.6	18	20
0	15.6	18	20
1	15.6	18	20

# Wiring Schematics

Standard product wiring diagram shown. As-built product wiring may vary. Product wiring diagram located on starter enclosure.

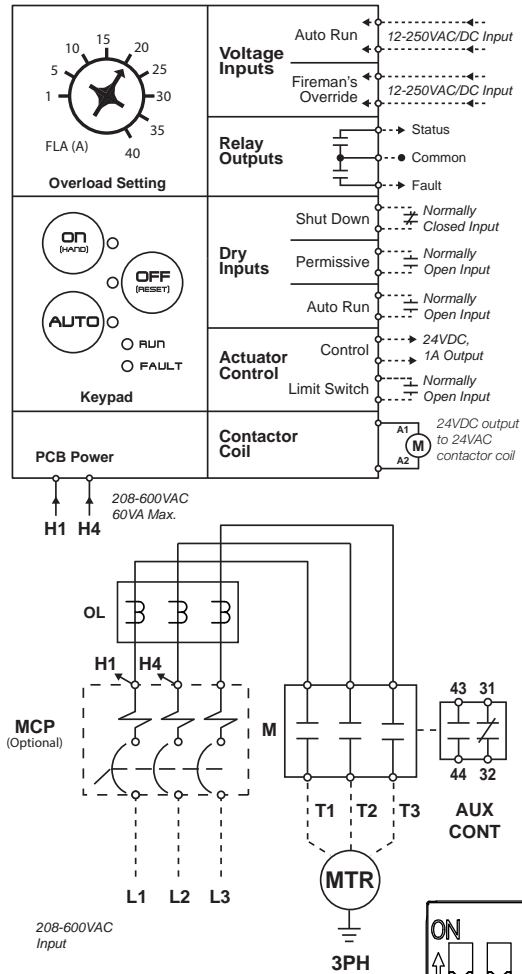

## Program Switches

<b>SWITCH 1</b>	Smartstart Bypass: Bypasses the Smartstart features when on. Smartstart protects the motor by detecting several common potentially damaging fault conditions. When Smartstart is active, the starter will shut off under the following conditions: if locked rotor condition is present for 0.5 seconds, if the motor takes more than 10 seconds to start, or if the FLA setting is determined to be incorrect.	
<b>SWITCH 2</b>	Selects overload trip Class 10 when on and overload trip Class 20 when off. If trip Class 20 is selected Smartstart is bypassed. Default: ON	
<b>SWITCH 3</b>	(ON) - Fault reset: Depress the "OFF" button for 5 seconds to reset a fault trip. Starter will return to "OFF" mode. (OFF) - Automatic Fault Reset: The starter will make 3 attempts at an auto fault reset separated by 5 minutes intervals. Also allows manual reset as above.	
<b>SWITCH 4</b>	<b>Power Fail Modes</b>	
<b>SWITCH 5</b>		
ON ON		Default Mode - Always return to last mode with no delay in the event of a power failure.
OFF OFF		Default Mode - Always return to last mode with no delay in the event of a power failure.
ON OFF		Always return to last mode with a 10 second delay in the event of a power failure.
OFF ON	Upon a power failure, return to off mode.	

## Protective Features

<b>Cycle Fault</b>	Trips when the starter is activated at a rate exceeding 20 starts per minute.
<b>Short 24V</b>	Trips if the starter's combined current drawn from the 24VDC damper actuator terminals and contactor terminals exceeds 1 amp.
<b>Locked Rotor</b>	Trips when a locked rotor condition is detected for 0.5 seconds (Smartstart mode only).
<b>Max Start Time</b>	Trips if the motor takes more than 10 seconds to start (Smartstart mode only).
<b>Out of Calibration</b>	Trips if the FLA setting is determined to be incorrect based on the motor inrush current (safety start mode only).
<b>Stall</b>	Trips if a STALL condition is detected. (0.5 seconds at 300% FLA and current slope not decreasing). Disabled during startup.
<b>Overload</b>	Overload trip Class 10 or 20. Trip current = 115% of FLA. Trips when the load is greater than the Full Load Ampere setting labeled FLA- (1-40A). The trip time will be determined by the Class 10/20 DIP switch.
<b>Phase Unbalance</b>	Trips in the event of a phase failure or phase unbalance greater than 70% (Smartstart mode only)

## Electronic Overload Operation

When an alarm occurs, the type of alarm will be indicated by flashing a combination of the hand/off/auto LED's as indicated in the table.

Fault	Hand	Off	Auto
Cycle Fault Alarm	-	-	-
Short 24V Alarm	-	-	0
Locked Rotor Alarm	-	0	-
Max Start Time Alarm	-	0	0
Out of Calibration Alarm	0	-	-
Stall Alarm	0	-	0
Overload Alarm	0	0	-
Phase Unbalance Alarm	0	0	0

- = off    0 = on

\*Run and Fault LED's will blink together in the event of a hardware fault.

### DANGER



- Ensure that all connections are properly torqued and enclosure is closed prior to applying power to the device.
- Ensure all mechanical equipment operated by the starter is clear for safe operation in case of starter activation.
- When in AUTO mode, starter may be activated remotely by the control system.

## Operation

- Intended for use with 3-Phase, 50/60Hz
- Accepts 208-600VAC,  $\pm 10\%$
- **Short Circuit (RMS, Symmetrical)**  
Stand-Alone Overload Unit - 200 KAIC, 600V Max.  
Standard Starter - 5 KAIC, 600V Max  
Combination Starter - 100 KAIC, 240V Max.  
30 KAIC, 480V Max.  
10 KAIC, 600V Max.
- Ambient Operating Temperature =  $-20^{\circ}\text{C}$  to  $60^{\circ}\text{C}$
- Ambient Storage Temperature =  $-40^{\circ}\text{C}$  to  $85^{\circ}\text{C}$

## Keypad Interface

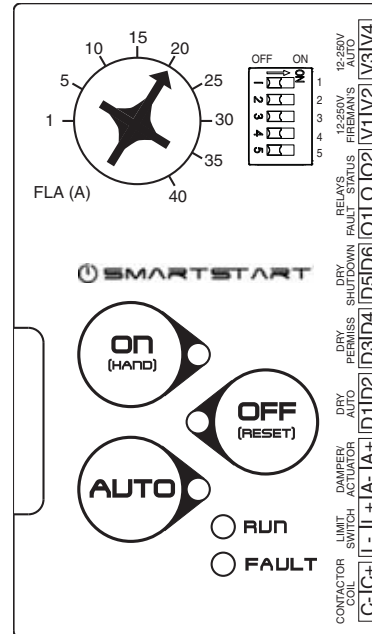

### NOTE

On NEMA-4X Enclosures, the interface is inside the enclosure. Do not attempt to remove the keypad on exterior of enclosure.

## Operation Modes

**ON (HAND):** Press the ON mode button to manually engage motor.

**OFF (RESET):** Pressing the OFF mode button manually disengages the motor. Additionally, the OFF button serves as a manual Reset. Press and hold OFF for 5 seconds to Reset the starter after a fault trip.

**AUTO:** When utilizing AUTO mode, the starter is controlled by a remote Start/Stop command.

## LED Status Indicators

**MODE LEDs:** Illuminates with corresponding mode selection (HAND/OFF/AUTO). Flashing mode LED signals a fault trip during the last operating mode. All three mode LEDs will flash simultaneously during Shutdown or Fireman's Override operation.

**RUN LED:** Illuminates when starter is given a Run signal and proof of flow is detected. LED will flash when Run signal is present without proof of flow to motor.

**FAULT LED:** Illuminates upon a fault condition or overload trip. Starter must be returned to the OFF mode in order to Reset.

## I/O Descriptions

- Use 14-26AWG wire for I/O terminals
- Torque to 3.5 lb-in

Terminal	Description
V3 / V4	<b>Wet Auto Input:</b> Accepts wetted customer input. Input voltage must be within 12 - 250 VAC/VDC (4.2mA maximum). Sending voltage to the contact will operate the starter when in Auto Mode.
V1 / V2	<b>Fireman's Override Input:</b> Accepts wetted customer input. Input voltage must be within 12 -250 VAC/VDC (4.2mA maximum). Sending voltage to the contact will operate the Motor Starter in all modes including OFF and Shutdown Input. When active, all mode LED's flash.
O1 / O / O2	<b>Status and Fault Relay Output</b> - O1 - Fault Terminal: Connects to a relay contact that closes in a fault condition. O - Common: Common connection for the fault and status relays. O2 - Run Status: Connects to a relay contact that closes when the motor draws 60% of the FLA setting. See below for Relay Output current ratings 110VDC, 0.3A Resistive 125VDC, 0.5A GP 30VDC, 2.0A Resistive 120VAC 50/60Hz, 0.5A Resistive 125VAC 50/60Hz, 1.0A GP 240VAC 50/60Hz, 0.25A Resistive
D5 / D6	<b>Dry Shutdown Input:</b> When the input is open the Motor Starter will open in all modes (except Fireman's Override), HAND/OFF/AUTO LED's will flash indicating a shutdown. (N.C. dry contact or transistorized input)

Terminal	Description
D3 / D4	<b>Dry Permissive Auto Input:</b> N.O. dry contact input. When the input is open, the Auto input is disabled. 24VDC, 2.4mA maximum
D1 / D2	<b>Dry Auto Input:</b> N.O. dry contact or transistorized input. When closed, the starter will operate when automatic mode is selected. 24VDC, 2.4mA maximum
A- / A+	<b>Damper Control Output:</b> 24VDC 1A maximum. Provides a 24VDC damper control output when the motor starter is commanded in either auto or hand mode. The damper control output must be wired with a damper end switch input as noted below to prevent overloading of control circuit.
L- / L+	<b>Damper Switch Input:</b> N.O. open dry contact. Switch input dry contacts must be rated for at least 24VDC, (2.4mA maximum). When used with the damper motor output, the contactor coil is in series with customer provided damper contacts which disable the motor starter until the damper is in position.
C- / C+	<b>Contactor Output:</b> Provides a 24V output to the contactor when the motor starter is commanded in either Hand or Auto mode and the damper switch input is closed. (Wired from manufacturer). 24V, 0.42A Max. for a Franklin Control Systems contactor with 24VAC coil.



To conform to the EMC directive, a ferrite core is required on the input of the starter module. Consult the factory for the recommended part number.  
 For a CE compliant installation, all electrical connections must be made by a qualified electrician.

## Our Commitment

*As a result of our commitment to continuous improvement, Greenheck reserves the right to change specifications without notice.*

Specific Greenheck product warranties are located on greenheck.com within the product area tabs and in the Library under Warranties.

Greenheck Motor Starters catalogs provides additional information describing the equipment and specification data.

AMCA Publication 410-96, Safety Practices for Users and Installers of Industrial and Commercial Fans, provides additional safety information. This publication can be obtained from AMCA International, Inc. at [www.amca.org](http://www.amca.org).

