

FumeJet® Exhaust Systems Models FJC and FJI

- Pre-engineered, single source responsibility
- Lower cost, simplified installation

FUMEJET®
by GREENHECK

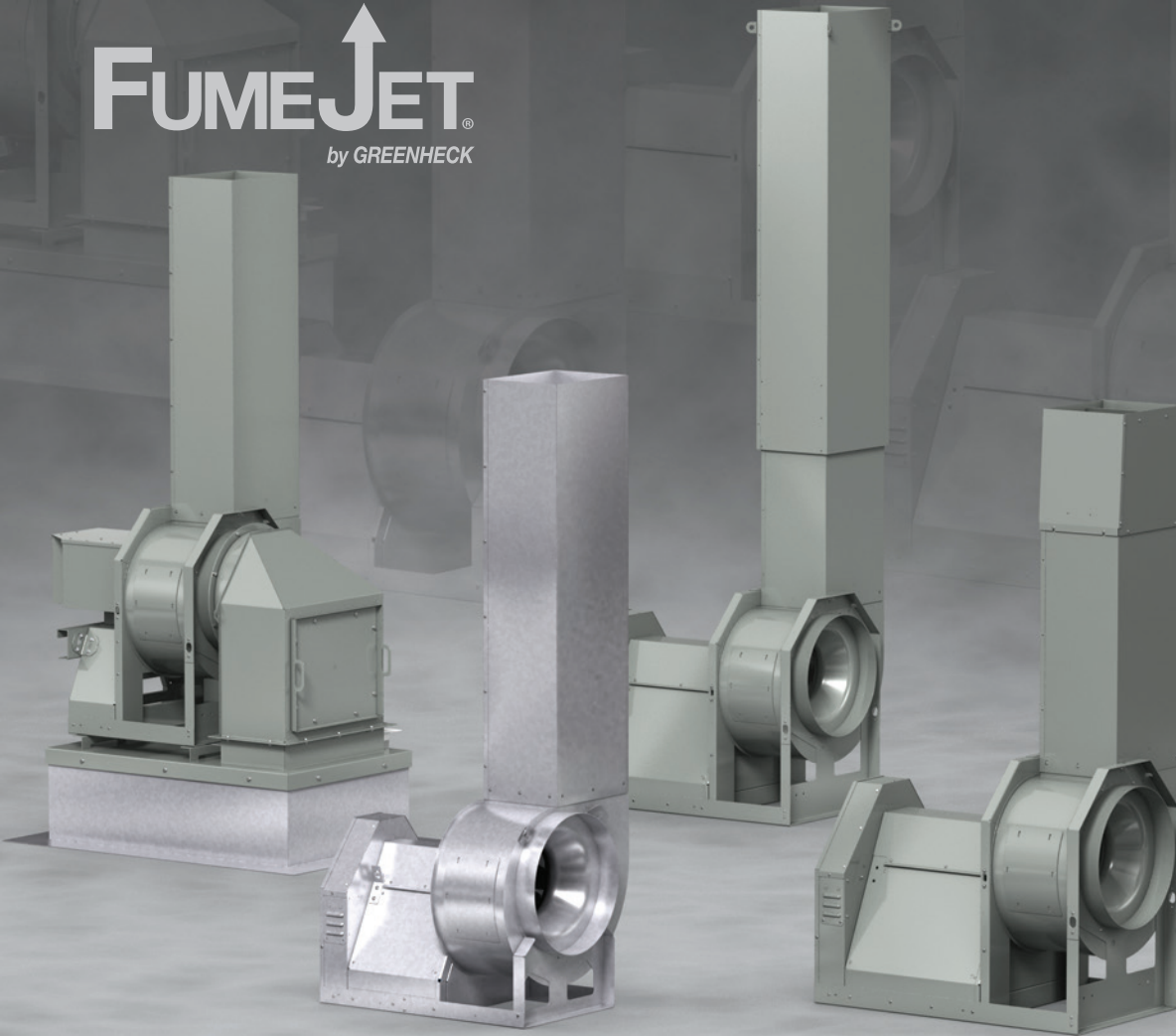

BUILDING VALUE IN AIR.

 **GREENHECK**
Building Value in Air.

April
2022

Greenheck's FumeJet® line of exhaust fans with integral stacks are designed to safely remove and disperse fumes and odors. FumeJet systems replace utility set fans with field supplied intake ducts and exhaust stacks to ensure a safe roof deck area and aid in preventing re-entrainment of contaminated air into air intake systems.



FJC-300 belt drive with coated steel and straight stack

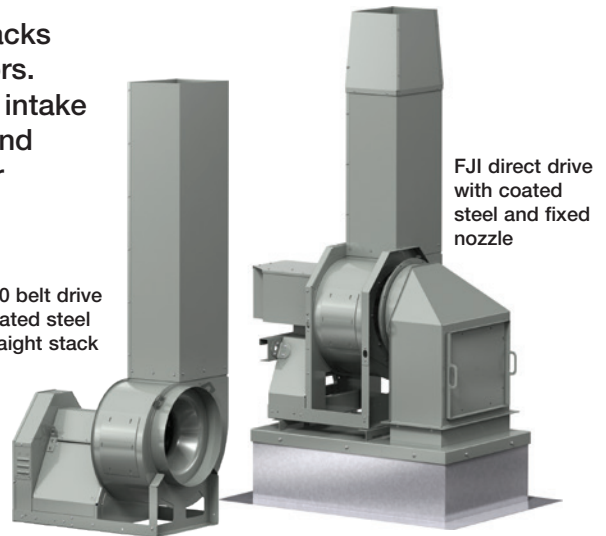

FJC – Performance up to 5,000 cfm (2,360 l/s) and 4.5 in. wg (1,120 Pa)

FJI – Performance up to 18,000 cfm (8,500 l/s) and 9 in. wg (2,240 Pa)

Value Added Advantages of Greenheck's FumeJet System	FumeJet	Field Built-up
Compact design	✓	
Single source responsibility – Eliminating component misapplication, performance and fit-up issues due to field-fabricated or sourced components	✓	
Designed to match application	✓	✓
Known performance corrections for all system components	✓	
Wind loading capacity designed and factory tested to withstand a force of 34 PSF (equivalent to 115 mph or 185 Km/h) without the need for guy wires	✓	
All FumeJet systems have a minimum of 7 ft. (2.1 m) exhaust discharge height. Optional 10 or 15 ft. (3 or 4.6 m) heights available	✓	
Corrosion Resistant Coating – All steel components are electrostatically powder coated with corrosion resistant Permator™ or Hi-Pro Polyester. Both protect against a wide spectrum of acids, alkalis and solvents	✓	

Eliminate Inefficient, Complicated and Unsafe Field Built-up Installations



Field-built systems can lead to complicated installations, unsafe exhaust locations, and even excess energy usage due to the creation of system effects. FumeJet pre-engineered exhaust systems include the necessary mounting accessories to simplify installation because equipment supports, isolators and curbs are designed specifically for the system. Additionally, all FumeJet performance data includes losses associated with inlet boxes, dampers, and stacks to prevent unexpected performance issues, drive changes, or motor change-outs during test and balance.

Fumes exhausted above working area for safe roof deck and over any MUA or air intakes to prevent reintraintment back into the building. Designed per ANSI Z9.2 standard for local exhaust systems, models FJC and FJI provide a compact footprint, complimentary accessories for quick and trouble free installation, and configurable mounting options to suit different building layouts.

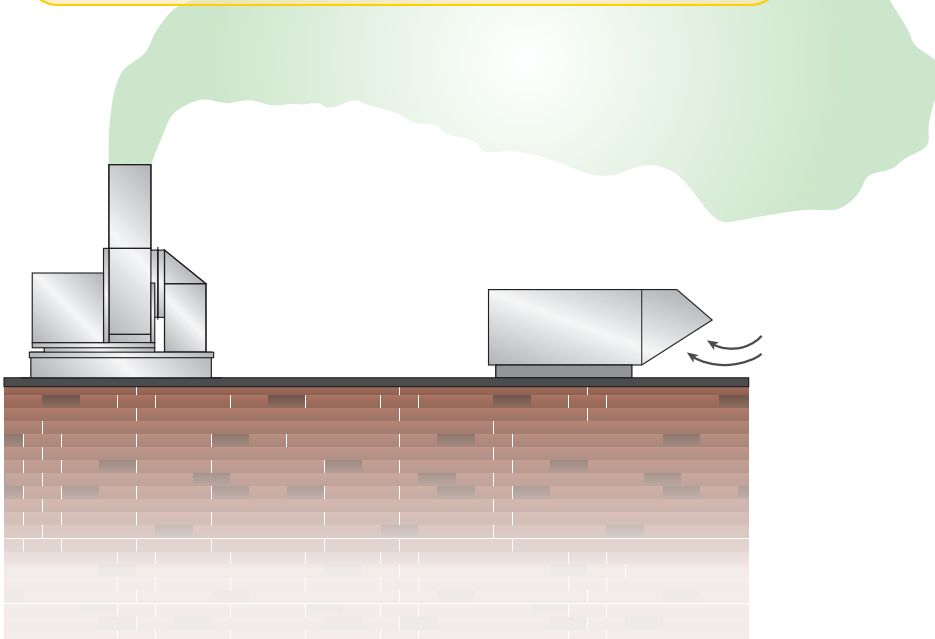

Selection software uses project volume with selected FumeJet configuration to provide effective plume height values.

FJI with mega stack option - 115 mph windload rating without guy wires

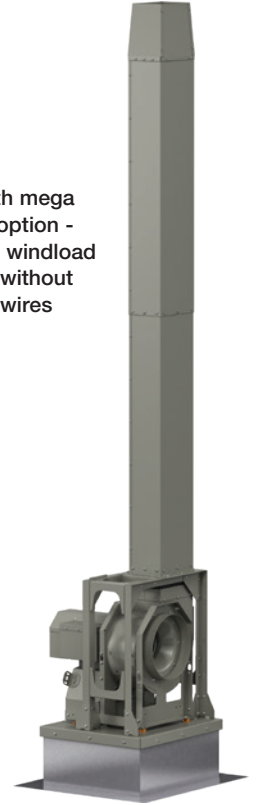

FJC belt drive shown with optional restrained isolators and equipment supports

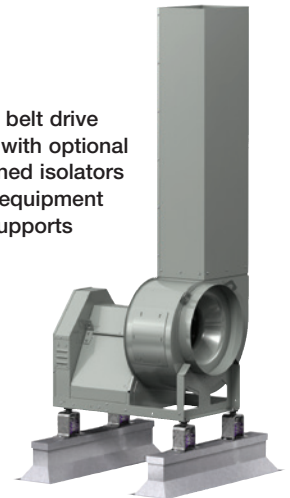

Commercial Facilities

- Smoke
- Hospital / clinic
- Sterilization
- Gun ranges
- Pharmacy

Industrial Facilities

- Food packaging
- Welding
- Paint systems
- Waste water / odor
- Indoor horticulture

Spark-Resistant Construction

Spark B	The fan wheel is constructed of a non-ferrous material (usually aluminum). A non-ferrous (aluminum) rub ring surrounds the fan shaft where it passes through the fan housing.
Spark C	The inlet cone is constructed of non-ferrous material (usually aluminum). A non-ferrous (aluminum) rub ring surrounds the fan shaft where it passes through the fan housing.

Protective Coating Options

Chemical Resistance Ratings						
Chemical	Bleach	Sulfuric Acid (10%)	HCl (10%)	MEK	Chlorine (0.1%)	NaOH (20%)
Permatector™	0	1	2	2	0	—
Hi-Pro Polyester	0	0	0	1	0	—
RATING DESCRIPTIONS	0 - No effect 1- Slight change in gloss or color 2- Surface etching, severe staining, but film integrity remains 3- Significant pitting, cratering, swelling, or erosion with obvious surface deterioration					

Pre-Engineered Discharge, Intake, and Easy Installation

Greenheck's FumeJet® systems are designed for quick installation and pre-engineered to eliminate component misapplication and fit-up issues. Build an application-specific FumeJet by selecting from multiple stack, discharge and intake options.

Fan Options

FJC-300

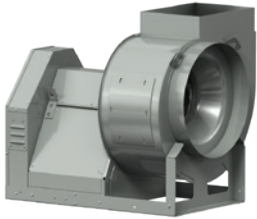

Belt-driven, arrangement 10, available in either bolted or welded construction. Compact footprint with motor and drives located under a common weatherhood.

Performance up to 5,000 cfm (2,360 l/s) and 4.5 in. wg (1,120 Pa)

FJI



Available in belt or direct drive, arrangement 10 or 4, AMCA class 0, I or II. Options for spark resistance, high temperature or corrosive exhausts.

Performance up to 18,000 cfm (8,500 l/s) and 9 in. wg (2,240 Pa)

VFD Speed Control Option

Available variable frequency drive (VFD) is preprogrammed at the factory for job specific conditions allowing for seamless installation. VFD comes standard with a NEMA-3R enclosure and integral disconnect. Selectable with unit mounting bracket or as remote mounted.



Multiple control options are available including:

- Remote Speed Dial
- Temperature & Humidity
- Constant Pressure
- Constant CFM
- VOC Air Quality Sensor



Stack Options



Standard



7 or 10 ft.

Integral stack to create a selectable 7 ft. or 10 ft. overall system discharge height.

Mega

(available on FJI only)

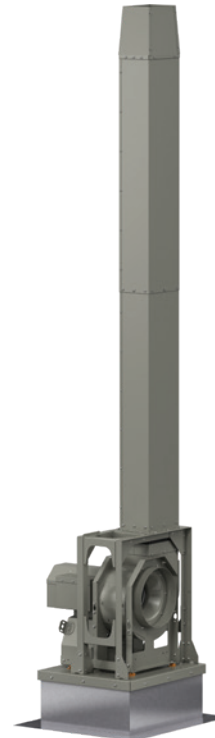

10 or 15 ft.

Self-supported stack for up to 15 ft. overall discharge height, ideal for low flow applications requiring higher plume rise. Fan is completely isolated from stack.

Discharge Options

Straight Stack

Clean design with uniform straight discharge stack. Most economical discharge option.



Fixed Nozzle

Tapered nozzle discharge increases outlet velocity sending exhaust fumes higher above the roof deck area. Does not negatively impact fan performance.



Adjustable Nozzle

Allows the user to adjust the discharge area based on installed conditions. Four blade positions available.

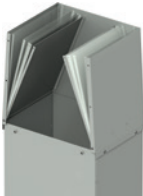

No Loss Stack

A lower velocity stack with NO pressure drop that sheds rain water away from the fan housing.



Intake Options

Horizontal Connection



Typically used with remote fan mounting locations and ducting run along the roof deck. Slip fit or flanged connection to fan inlet. Recommended installation with three wheel diameters of straight duct prior to inlet to prevent airflow system effects.

Vertical Connection Curb Cap Inlet Box



Positions the exhaust fan over the roof penetration. Compact installation minimizes roof deck space and leakage from multiple roof penetrations. Duct support provided to install duct drops in roof curb. Optional backdraft damper prevents airflow back into the building when fan is not in operation.



Easy Installation

FumeJet with restrained isolators and GESS equipment supports

Minimal on-site assembly required for FumeJet systems. Exploded views reflect shipping splits.

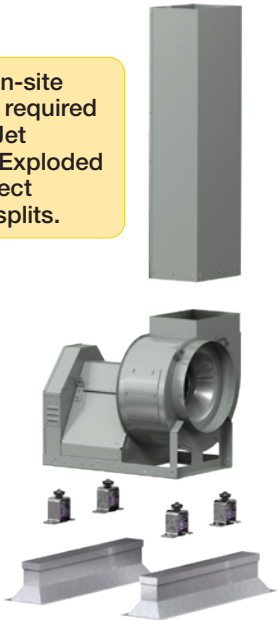

FumeJet with curb cap inlet box and GPFHL roof curb

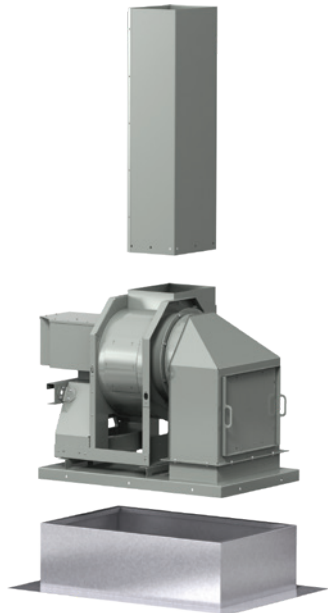

Standard and Optional Construction

Housing & Impeller Specs	FJC	FJI
Housing Type	Scroll Housing	Scroll Housing
Impeller Type	Backward Inclined Centrifugal	Backward Inclined Centrifugal
Impeller Sizes	6-15 Inch	7-24 Inch
Finish Types	Galvanized, Coated Steel	Coated Steel
Spark Resistance	None, Spark B or C	None, Spark B or C
Construction Class	N/A	0, I, II
Housing Construction	Permalock™	Permalock™ or Welded
Drain	1 in. Drain Hole	1 in. Threaded Drain Connection
Coating (optional)	Permatector™ or Hi-Pro Polyester	Permatector™ or Hi-Pro Polyester
Power Transmission Specs		
Motor Enclosure	ODP, TEFC	ODP, TEFC, EXP
Arrangements	Belt Drive (arrg. 10)	Belt (arrg. 10) or Direct Drive (arrg. 4)
Bearing Life (Hours)	L ₁₀ 80,000	L ₁₀ 80,000 or L ₁₀ 200,000
Shaft Material	Turned & Polished Steel	Turned & Polished Steel
Shaft Bearings	Set screw	Concentric lock
Discharge		
System Height	7 ft. (2.1 m) – Standard 10 ft. (3 m) – Extended	7 ft. (2.1 m) – Standard 10 ft. (3 m) – Extended, Mega 15 ft. (4.6 m) – Mega
Nozzle	Straight, Fixed, Adjustable, No Loss	Straight, Fixed, Adjustable, No Loss
Performance Specs		
CFM Range (Min CFM)	200 cfm (95 l/s)	200 cfm (95 l/s)
CFM Range (Max CFM)	5,000 cfm (2,360 l/s)	18,000 cfm (8,500 l/s)
Pressure (Ps Max)	4.5 in. wg (1,120 Pa)	9 in. wg (2,240 Pa)
Factory Vibration Test (peak vibration, at fan rpm, filter in)	None	.15 in/s (belt) or .08 in/s (direct)
Continuous Max Temp (Optional)	400°F (204°C)	500°F (260°C)
Controls		
Speed Control (Optional)	Variable Frequency Drive (Factory Programmed)	Variable Frequency Drive (Factory Programmed)
Certifications		
AMCA Air Performance	Sizes 6-8	-
AMCA Sound and Air Performance	Sizes 12-15	Sizes 7-24
UL/cUL 705 Listed Power Ventilator	Optional	Optional
High Wind Rating	115 mph (185 Km/h)	115 mph (185 Km/h)
California OSHPD Seismic	OSP-0503-10	-
Miami-Dade Notice Of Approval (NOA)	17-0307.01 (Without stack/nozzle)	-
Florida Product Approval (FLPA)	FL22703	-
Quick Ship Programs	5 day	10 day

- 1 **Access Door** – Bolted or hinged removable panel provides access for inspection or cleaning.
- 2 **Inlet Flange** – Fan inlet is flanged for bolted connection to system ductwork.
- 3 **Companion Inlet Flange** – For easy connection between inlet flange and system ductwork. Companion and inlet flange have matching bolt hole pattern.
- 4 **Restrained Spring Isolators** – Both vertical and lateral movement restricted. Isolators are seismically rated to minimum 1.0 g, and sized for all components including stack.
- 5 **Equipment Supports** – Model GESS equipment supports designed for use on non-insulated flat roof decks and mounted directly to the deck structure. Available in galvanized steel.
- 6 **Curb Cap Inlet Box (CCIB)** – Provides a quick transition from roof opening to fan inlet often used in locations with minimal roof deck space. Coated steel construction with fully welded seams and corners.
- 7 **Backdraft Damper** – Located in the roof curb, the gravity damper prevents airflow back into the building when the fan is not in operation.
- 8 **Duct Drop** – Transition between building ductwork and inlet box opening. Coated and fully welded duct drop supplied with matching flange to inlet box and slip-fit end for easy field duct connection. Multiple lengths available for extending below roof deck if desired.
- 9 **Roof Curb** – Model GPFHL is a straight sided, insulated roof curb with internal vertical supports designed for high loads. Roofing material is brought to the vertical surface and sealed to the flashing flange.
- 10 **Disconnect Switch** – NEMA-3R rated disconnect switches. Switches can be factory mounted or shipped loose for field installation.
- 11 **Sure-Aire™ (FJI)** – Airflow measurement device (piezometric ring) with an accuracy within 3%. Unlike traditional flow probes mounted in the fan venturi, Sure-Aire does not create a system effect hindering fan performance. Optional Sure-Aire Monitor (ships loose) for reading the fan performance. Resulting data can be tied to the facility Building Automation System (BAS).
- 12 **Motor Starter** – Starter components options include: physical interface, overload protection, disconnect, magnetic contactor, NEMA-1 or NEMA-3R steel enclosures and pre-engineered easy system integration.
- 13 **Fan Monitoring System (ships loose)** – The FMS package includes a preprogrammed monitor along with a wide selection of commonly applied sensors to monitor the overall equipment health, plan maintenance, and monitor energy use.
- 14 **Variable Frequency Drive (VFD)** – Factory programmed for job specific conditions. Includes integral disconnect and NEMA-3R enclosure with multiple control options available. Optional mounting bracket accessory.

Shaft Seal – Felt or neoprene shaft seal with rub ring available for operation at high temperatures or exhausting contaminated air. Seal prevents contaminated exhaust from leaking into the surrounding area. (not shown)

Extended Lube Lines – Conveniently located grease fittings mounted on the exterior of weatherhood or motor cover. Nylon or copper depending on airstream temperature. (not shown)

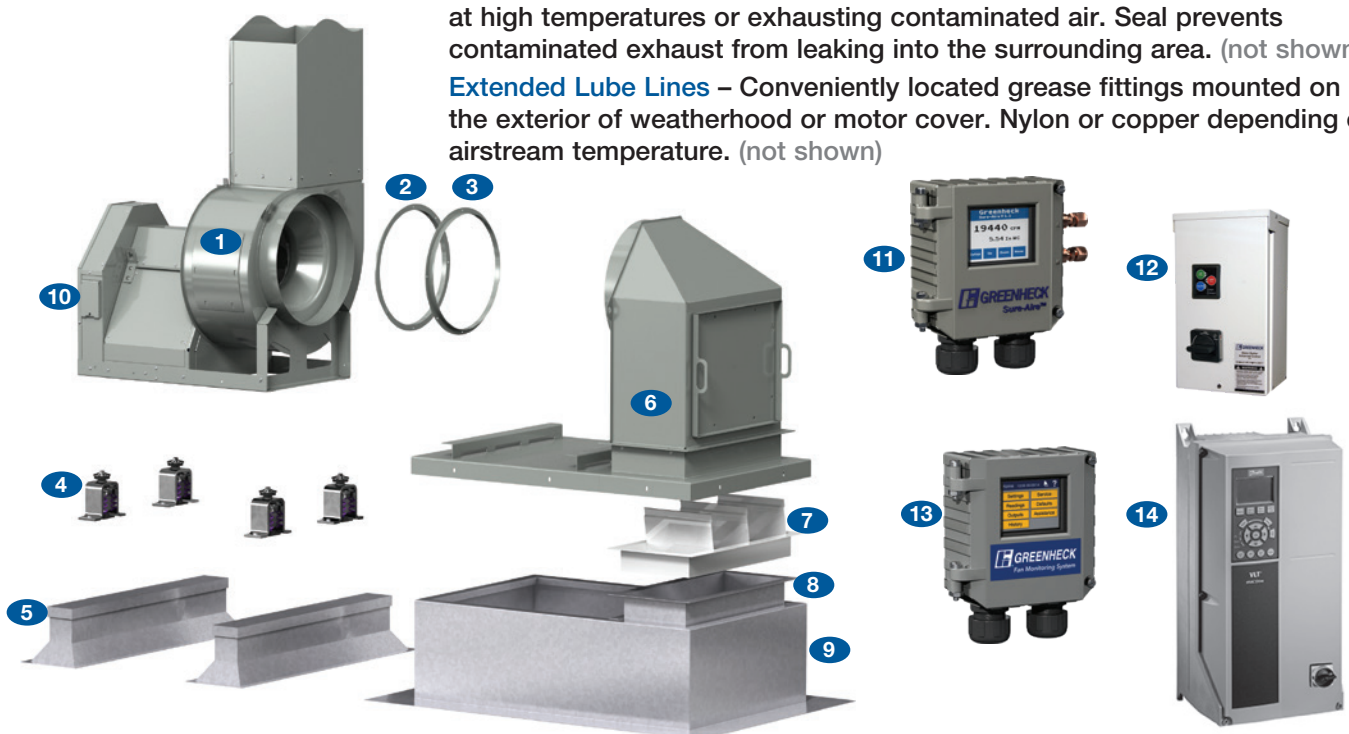

Benefits of the FumeJet[®] include single source responsibility, performance data that includes stack and accessory corrections, energy savings usage by elimination of system effects, and features to reduce the cost of installation.

FumeJet - Commercial Series

FJC - 3 24

Series

300

Fan Size

06 through 15

FumeJet - Industrial Series

FJI - 18 - BI - X

Fan Size

07 through 24

Wheel Type

BI & AF

Certification

None

X - UL/cUL 705 Listed (Electrical)

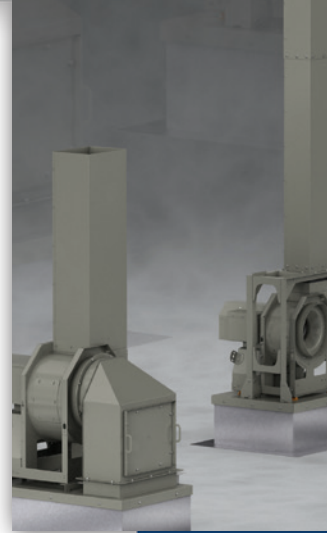

Our Commitment

As a result of our commitment to continuous improvement, Greenheck reserves the right to change specifications without notice.

Product warranties can be found online at Greenheck.com, either on the specific product page or in the literature section of the website at Greenheck.com/Resources/Library/Literature.

